

# Hydraulic Lift (Foot operated type)

## MLSH Ultra-low & Slim

Load capacity: 330 lbs

It is possible to directly place a hand-pushed cart or a flat cart currently in use on top of the lift. Work can be more efficient since there is no need to pile up items over again on the table lift.

### Major features of the MLSH Series

- Ultra-low platform
- Hydraulic cylinder
- Stand-alone unit
- Foot switch cord: 6.6 feet
- High-pressure hose: 6.6 feet
- Power cord: 13.1 feet (E-type)

### Major specifications

Oil used Turbine oil: ISO VG22 (H-type)

\* When the table is raised from the lowest position to the highest position, the table shifts up to 1.1 inch in the longitudinal direction (direction of L).



MLSH-150-2007

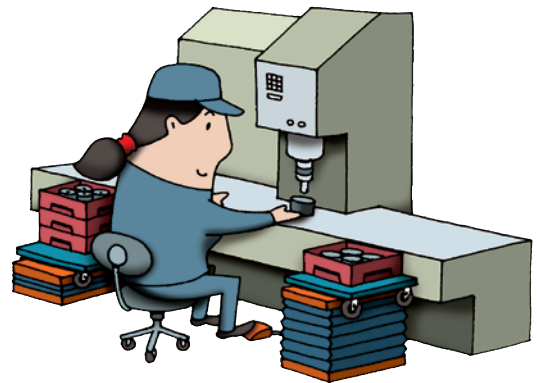

Adjust the height for work efficiency and improve productivity.

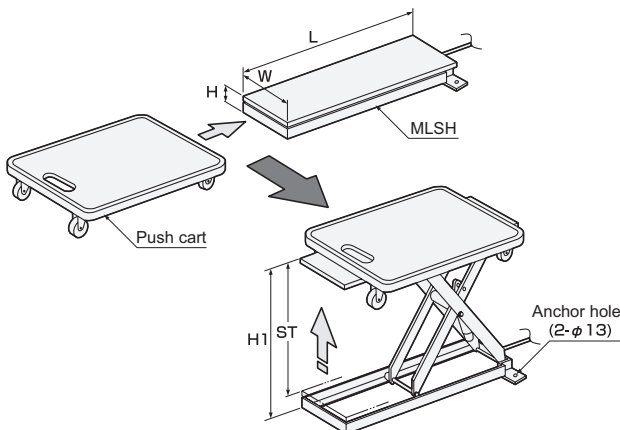

Unit: inch

	Model	Load capacity	Table dimensions W × L	Stroke (ST)	Table height (H to H1)	Number of pump steps	Deadweight
Ultra-low & Slim type	MLSH-150-2007	330 lbs	7.9×27.6	19.9	2.6 to 22.4	Approx. 25 times	88.2 lbs
	MLSH-150-2009		7.9×35.4	25	2.6 to 27.6		101.4 lbs