

HLFN Hydraulic/Manual Foot Pump Pallet Lift

By installing cylinders under the forks, we were able to eliminate the part of hydraulic unit from push handle area for stronger and safer design.



HLFN-500F

During Lowering

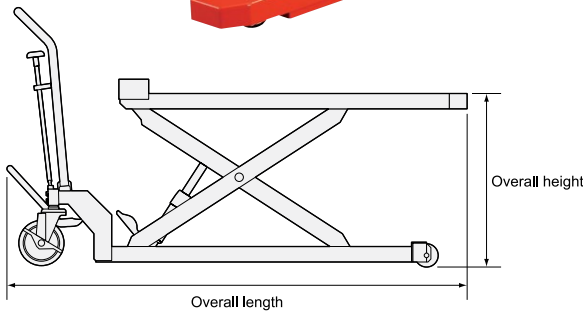
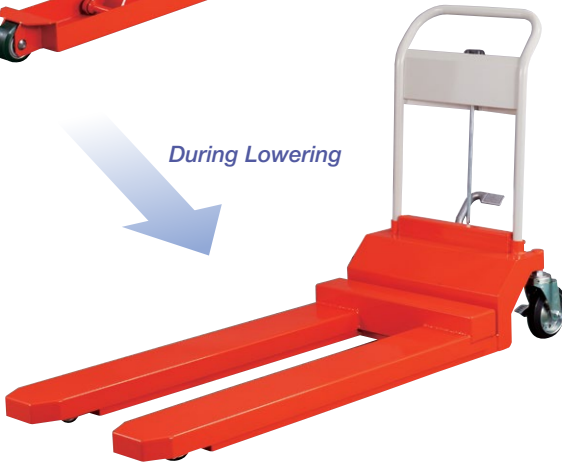

MAJOR FEATURES OF THE MLSH SERIES

- For open bottom pallet
- Hydraulic cylinder
- Swivel casters with brakes
- Foot pedal type
- Equipped with an overloading prevention device *1

MAJOR SPECIFICATIONS

Oil Used

Turbine oil: ISO VG22

*1 The lift will not elevate when overloaded.

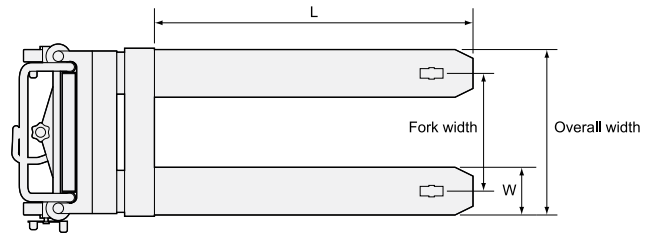

Load capacity: 1103 / 2205 lbs

Unit: inch

Fork Type	Model	Load capacity	Overall length	Overall width	Overall height	Fork dimensions (W x L)	Fork width	Fork height	Stroke (ST)	Wheels	Number of pump steps	Deadweight
										(Swivel caster / Rigid caster)		
	HLFN-500F	1103 lbs	60.2"	24.6"	33.9"	6.3"×41.3"	21.7"	3.4" to 21.1"	17.7"	Φ5.9 rubber / Φ3.0 urethane	Approx. 52	198.4 lbs
	HLFN-1000F	2205 lbs	64.6"	28.3"	39.4"	7.9"×42.5"	19.1"	3.5" to 23.6"	20.1"	Φ7.9 rubber / Φ3.1 urethane	Approx. 52	352.7 lbs