

# HLH Hydraulic/Manual Foot Pump

## Ultra-low

**A** vailable with increased standard stroke. Equipped with easy movement wheels. Lift table lowers to 3.2 inches.



HLH-100-80L



### MAJOR FEATURES OF THE HLH SERIES

- Hydraulic cylinder
- Casters with brakes
- Foot pedal type
- Overloading prevention device
- Nose dive prevention valve (HLH-100-80L only)

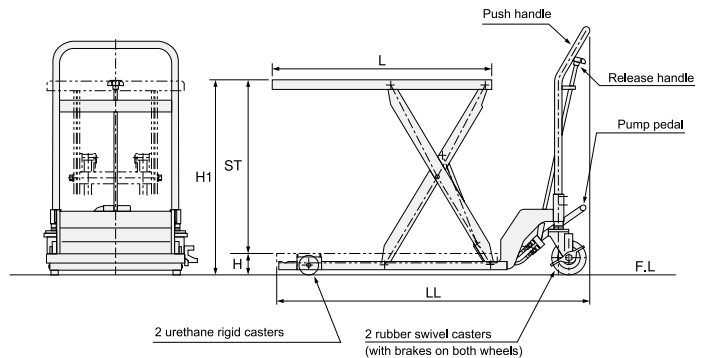
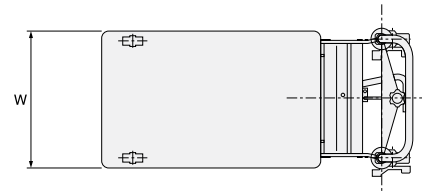

**Load capacity:** 220 to 881 lbs

Unit: inch

	Model	Load capacity	Table dimensions (W x L)	Stroke (ST)	Table height (H to H1)	Total Length (LL)	Wheel Dimensions		Number of pump steps	Deadweight
							Rigid Caster	Swivel Casters with brakes		
<b>Low Platform</b>	HLH-100-80L	220 lbs	15.7" x 28.3"	21.7"	3.2" to 24.9"	40.6"	φ3.0	φ3.9	Approx. 20	77 lbs
	HLH-200-80L	440 lbs	19.7" x 31.5"	24.8"	3.2" to 28.0"	44.9"	φ3.0	φ4.9	Approx. 46	125.7 lbs
	HLH-400-85L	881 lbs	23.6" x 35.4"	27.6"	3.4" to 31.0"	50.7"	φ3.0	φ5.9	Approx. 70	207.3 lbs

**Note** The swivel casters have rubber wheels and the rigid casters have urethane wheels.

**Note** HLH-100-80L has rubber wheels.