

# HLH Hydraulic/Manual Foot Pump Handle-less

**W**ith the handle removed from the standard type, this cart is ideal for loading long items.



During Lowering

HLH-200HL



### MAJOR FEATURES OF THE HLH SERIES

- Hydraulic cylinder
- Swivel casters with brakes  
(double stopper for models other than HLH-100HL and HLH-120HL)
- Foot pedal type
- Comes with an overloading prevention device \*1

### OPTION

- Pump with a rapid traverse device

### SPECIFICATIONS

#### Oil Used

Turbine oil: ISO VG22

#### Materials

Pump : Urethane type resin spray painting

Cylinder : Urethane type resin spray painting

Main body : Baked melamine / Powder coating

\*1 The lift will not elevate when overloaded.

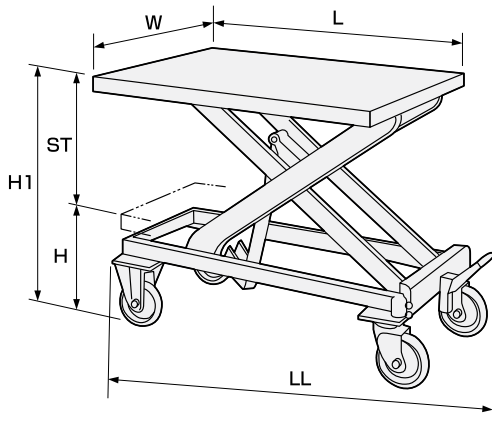

(Handle-less type pump diagram)

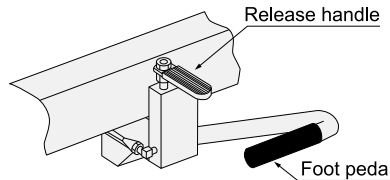

Useful for carrying long loads such as panels and poles.

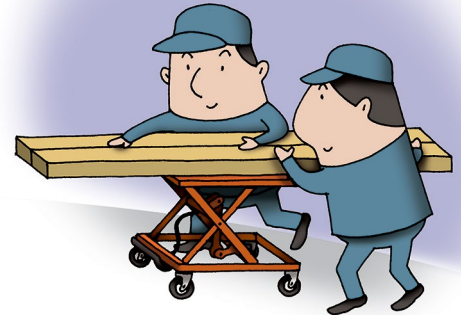

**Load capacity:** 220 to 441 lbs

Unit: inch

	Model	Load capacity	Table dimensions (W x L)	Stroke (ST)	Table height (H to H1)	Overall Length (LL)	Wheels	Number of pump steps	Deadweight
<b>Handle-less</b>	HLH-100HL	220 lbs	13.8"×22.4"	15.7"	7.9" to 23.6"	30.1"	φ3.9 rubber	Approx. 12	41.9 lbs
	HLH-120HL	264 lbs	15.7"×28.3"	19"	9.3" to 28.3"	36.6"	φ3.9 rubber	Approx. 22	66.2 lbs
	HLH-200HL	441 lbs	19.7"×31.5"	21.3"	10.3" to 31.4"	39.8"	φ3.9 rubber	Approx. 36	99.2 lbs

\* This cart is also available with bellows (except HLH-100HL).